



SE15TQ2BDDAH

ESD PROTECTION DIODE

FEATURES

- IEC61000-4-2(ESD) $\pm 30\text{kV}$ (air), $\pm 30\text{kV}$ (Contact)
- Bi-direction
- Low Clamping Voltage
- Low Reverse Current
- Suffix " H " indicated Halogen-free part, ex.SE15TQ2BDDAH

MECHANICAL DATA

Case : DFN1006(0402) mold package

PIN CONFIGURATION



Top View

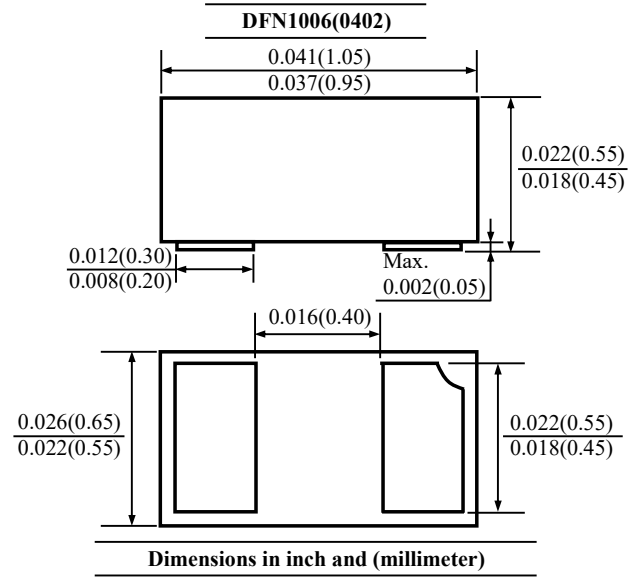

Maximum Ratings (Rating at 25°C ambient temperature unless otherwise specified)

Parameter	Symbol	Value	Units
Peak Pulse Power ($t_p = 8/20\mu\text{s}$)	P_{PP}	150	W
Peak Pulse Current ($t_p = 8/20\mu\text{s}$)	I_{PP}	5	A
ESD per IEC 61000-4-2 (Air)	V_{ESD}	± 30	kV
ESD per IEC 61000-4-2 (Contact)		± 30	
Operating Temperature Range	T_J	-55 to +125	°C
Storage Temperature Range	T_{STG}	-55 to +150	°C



SE15TQ2BDDAH

ESD PROTECTION DIODE

Electrical Characteristics Per line @ 25°C Unless Otherwise Specified

Parameter	Test Conditon	Symbol	Min.	Typ.	Max.	Units
Reverse Stand-Off Voltage	-	V_{RWM}	-	-	15	V
Reverse Breakdown Voltage	$I_R=1\text{mA}$	V_{BR}	16.7	-	-	V
Reverse Leakage Current	$V_{RWM}=15\text{V}$	I_R	-	-	1	μA
Clamping Voltage	$I_{pp}=1\text{A}, t_p=8/20\mu\text{s}$	V_C	-	-	22	V
	$I_{pp}=5\text{A}, t_p=8/20\mu\text{s}$		-	-	30	
ESD Clamping Voltage	$I_{TLP}=4\text{A}, t_p=0.2/100\text{ns (TLP)}$	V_C	-	20.8	-	V
	$I_{TLP}=16\text{A}, t_p=0.2/100\text{ns (TLP)}$		-	24.1	-	
Dynamic Resistance (Note 1)	-	R_{DYN}	-	0.28	-	Ω
Junction Capacitance	$V_R=0\text{V}, f=1\text{MHz}$	C_J	-	24	-	pF

Note :

1. Dynamic Resistance calculated from $I_{TLP}=4\text{A}$ to $I_{TLP}=16\text{A}$.



SE15TQ2BDDAH

ESD PROTECTION DIODE

RATINGS AND CHARACTERISTIC CURVES

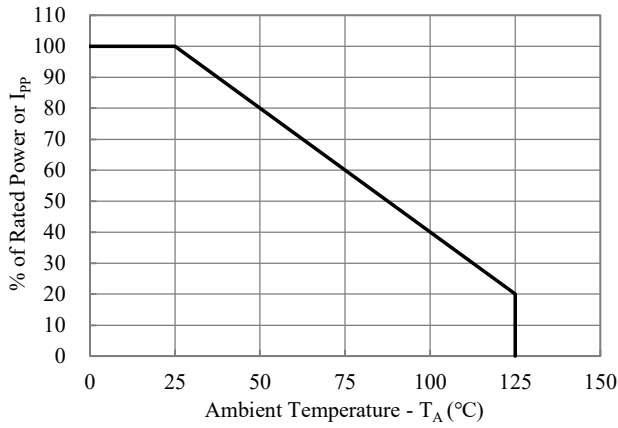

Fig. 1 Power Derating Curve

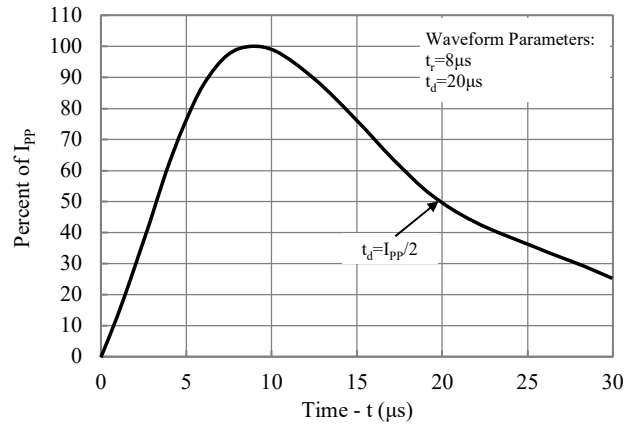

Fig. 2 Pulse Waveform

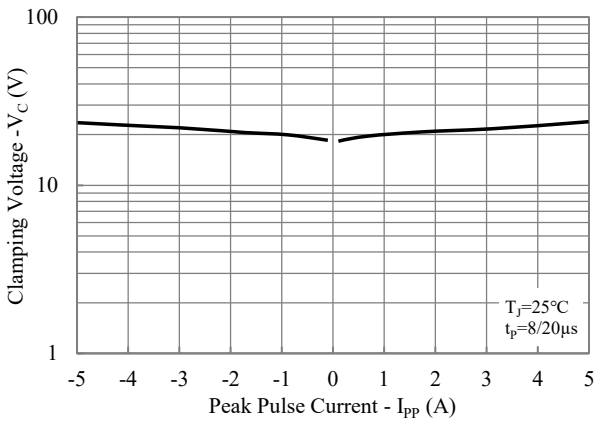

Fig. 3 Clamping Voltage vs. Peak Pulse Current

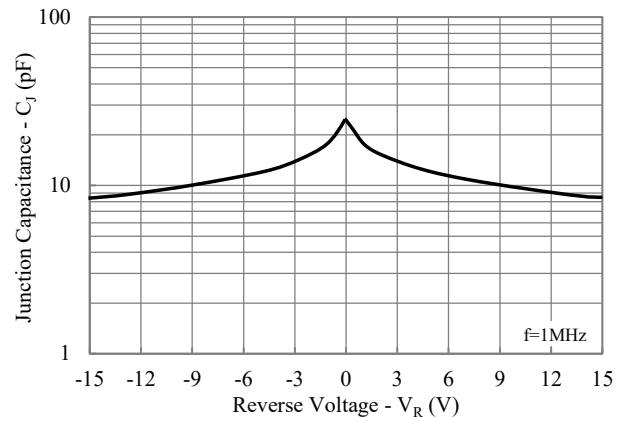

Fig. 4 Junction Capacitance vs. Reverse Voltage

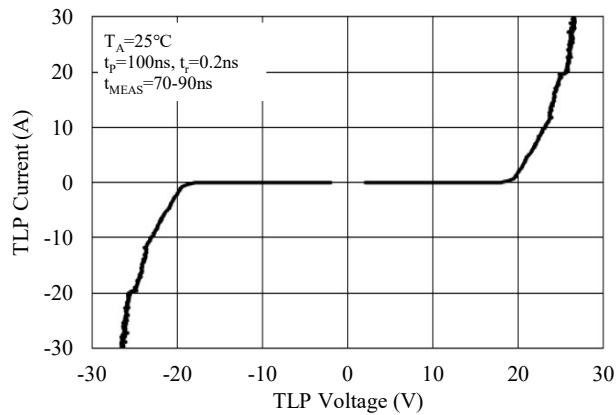

Fig. 5 TLP Characteristic



SE15TQ2BDDAH

ESD PROTECTION DIODE

TAPE & REEL SPECIFICATION

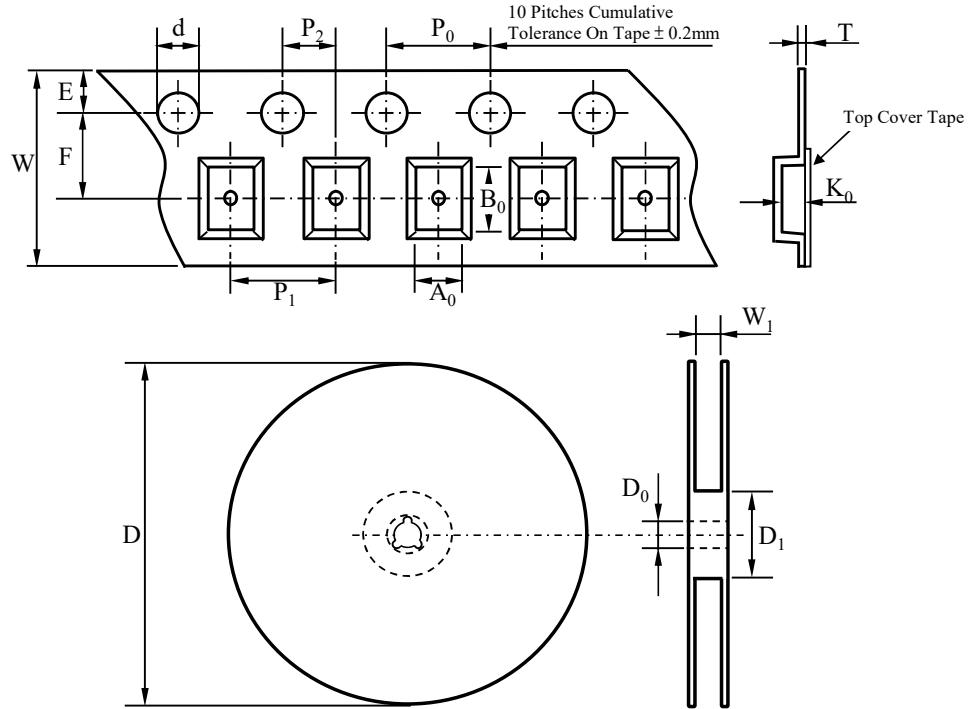

Item	Symbol	DFN1006(0402)
Carrier width	A_0	*
Carrier length	B_0	
Carrier depth	K_0	
Sprocket hole	d	1.50 ± 0.10
Reel outside diameter	D	178.00 ± 2.00
Feed hole width	D_0	13.00 ± 0.50
Reel inner diameter	D_1	MIN. 54.00
Sprocket hole position	E	1.75 ± 0.10
Punch hole position	F	3.50 ± 0.10
Sprocket hole pitch	P_0	4.00 ± 0.10
Punch hole pitch	P_1	2.00 ± 0.10
Embossment center	P_2	2.00 ± 0.10
Overall tape thickness	T	MAX. 0.60
Tape width	W	8.00 ± 0.30
Reel width	W_1	8.40 ± 1.50

Note *: A_0 , B_0 , and K_0 are determined by component size. The clearance between the components and the cavity must be within 0.05 mm min. to 0.5 mm max.

ORDER INFORMATION

Part Number	Marking Code	Reel Size	Quantity
SE15TQ2BDDAH	K4	7"	10,000



SE15TQ2BDDAH

ESD PROTECTION DIODE

SUGGESTED SOLDER PAD LAYOUT

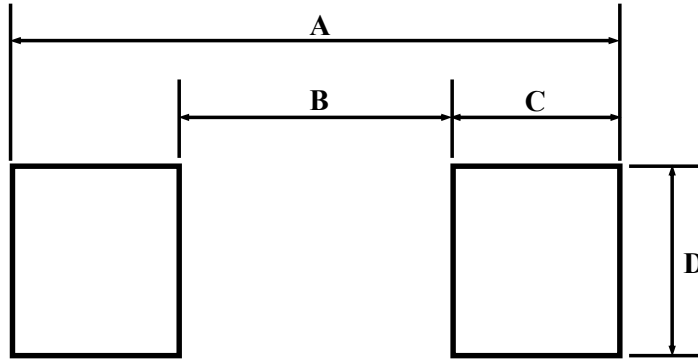

Unit :mm

PACKAGE	A	B	C	D
DFN1006	1.10	0.30	0.40	0.60