



SE12TQ7UDIH

ESD PROTECTION DIODE

FEATURES

- Low Clamping Voltage
- Suffix " H " indicated Halogen-free part, ex.SE12TQ7UDIH

APPLICATIONS

- Industrial Equipment
- Legacy Ports (RS-232, RS-485)
- Motor Controls
- Security and Alarm Systems

MECHANICAL DATA

Case : SOT-23

PIN CONFIGURATION

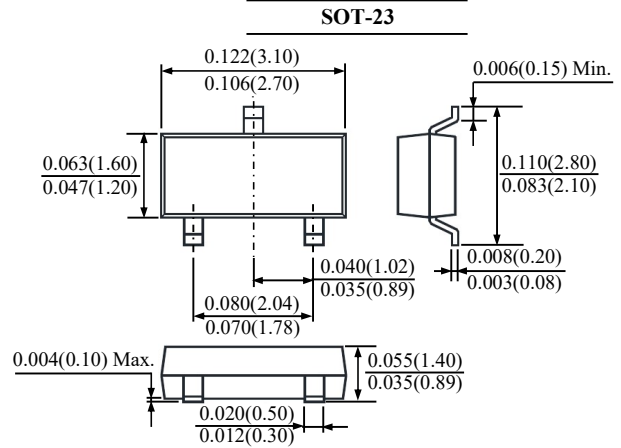
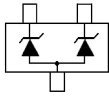

Dimensions in inches and (millimeters)

Maximum Ratings (Rating at 25°C ambient temperature unless otherwise specified)

Parameter	Symbol	Value	Units
Peak Pulse Power ($t_p=8/20\mu s$)	P_{PP}	300	W
Peak Pulse Current ($t_p=8/20\mu s$)	I_{PP}	12	A
ESD per IEC 61000-4-2	Air	± 15	kV
	Contact	± 8	
Operating Temperature Range	T_J	-55 to +125	°C
Storage Temperature Range	T_{STG}	-55 to +150	°C



SE12TQ7UDIH

ESD PROTECTION DIODE

Electrical Characteristics (Rating at 25°C ambient temperature unless otherwise specified)

Parameter	Test Condition	Symbol	Min	Typ.	Max	Units
Reverse Stand-Off Voltage	-	V_{RWM}	-	-	12.0	V
Breakdown Voltage	$I_R=1\text{mA}$	V_{BR}	13.3	-	16.0	V
Reverse Leakage Current	$V_{RWM}=12\text{V}$	I_R	-	-	1	μA
Clamping Voltage	$I_{pp}=1\text{A}, t_p=8/20\mu\text{s}$	V_C	-	-	19	V
	$I_{pp}=12\text{A}, t_p=8/20\mu\text{s}$		-	-	25	
ESD Clamping Voltage	$I_{TLP}=4\text{A}, t_p=0.2/100\text{ns}$ (TLP)	V_C	-	14.8	-	V
	$I_{TLP}=16\text{A}, t_p=0.2/100\text{ns}$ (TLP)		-	17.0	-	
Dynamic Resistance (Note 1)	-	R_{DYN}	-	0.18	-	Ω
Junction Capacitance	$V_R=0\text{V}, f=1\text{MHz}$	C_J	-	73	-	pF

Note :

1. Dynamic Resistance calculated from $I_{TLP}=4\text{A}$ to $I_{TLP}=16\text{A}$.

RATINGS AND CHARACTERISTIC CURVES

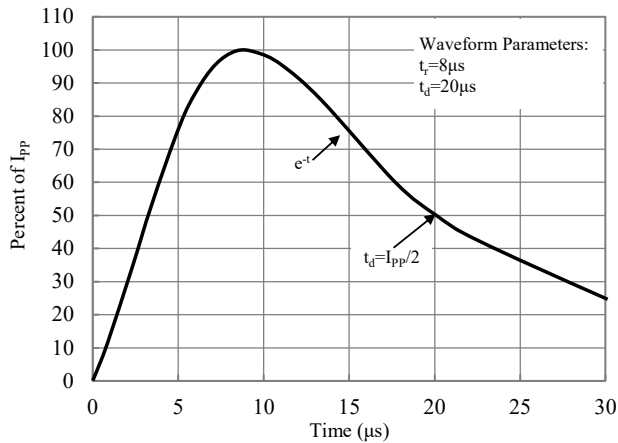

Fig.1-Pulse Waveform

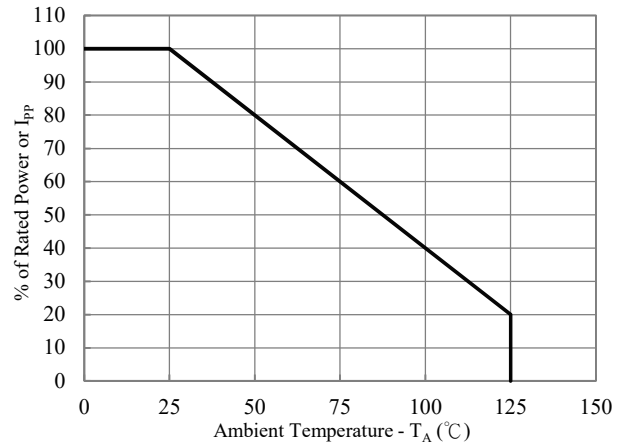

Fig.2-Power Derating Curve

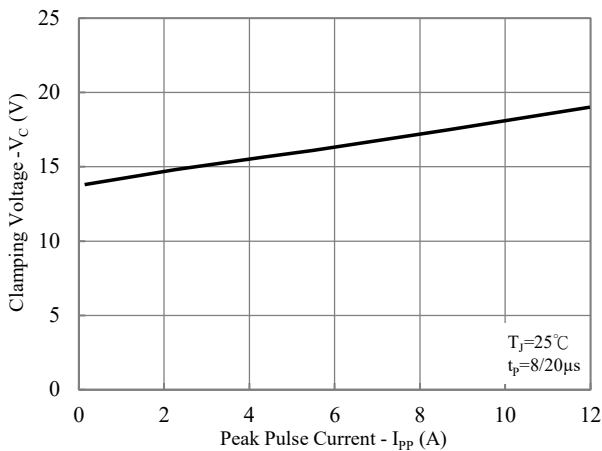

Fig.3-Clamping Voltage vs. Peak Pulse Current

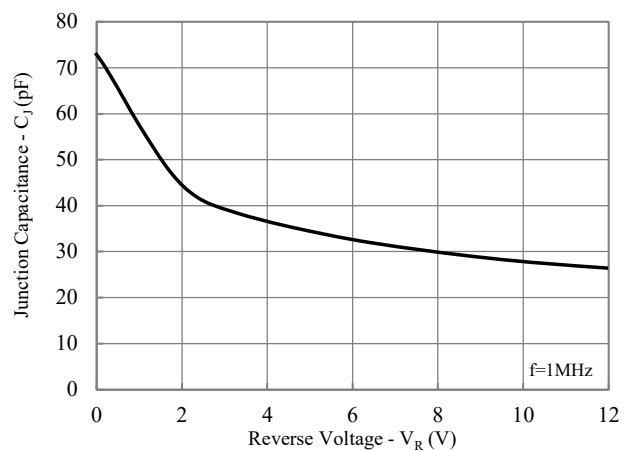

Fig.4-Junction Capacitance vs. Reverse Voltage



SE12TQ7UDIH

ESD PROTECTION DIODE

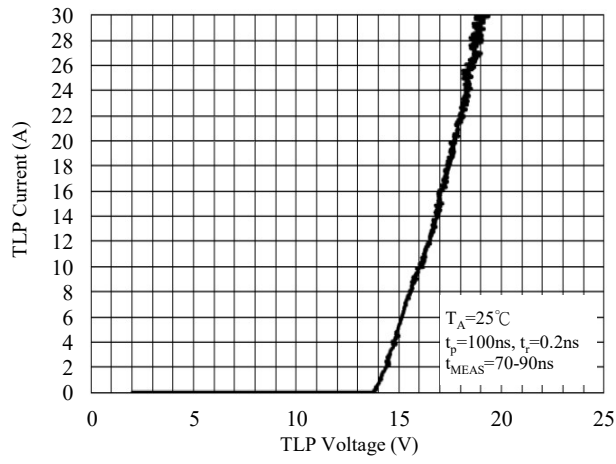

Fig.5-TLP Curve



SE12TQ7UDIH

ESD PROTECTION DIODE

TAPE & REEL SPECIFICATION

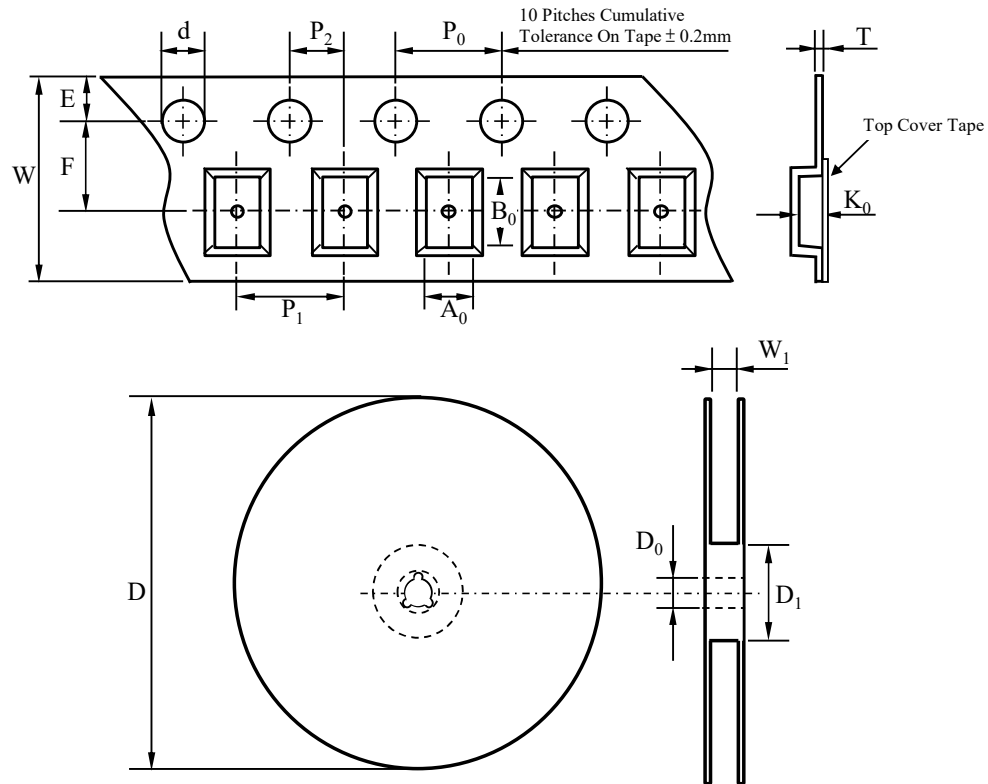

Item	Symbol	SOT-23
Carrier width	A_0	*
Carrier length	B_0	
Carrier depth	K_0	
Sprocket hole	d	1.50 ± 0.10
Reel outside diameter	D	178.00 ± 2.00
Feed hole width	D_0	13.00 ± 0.50
Reel inner diameter	D_1	MIN. 50.00
Sprocket hole position	E	1.75 ± 0.10
Punch hole position	F	3.50 ± 0.10
Sprocket hole pitch	P_0	4.00 ± 0.10
Punch hole pitch	P_1	4.00 ± 0.10
Embossment center	P_2	2.00 ± 0.10
Overall tape thickness	T	0.20 ± 0.05
Tape width	W	8.00 ± 0.20
Reel width	W_1	MAX. 14.50

Note *: A_0 , B_0 , and K_0 are determined by component size. The clearance between the components and the cavity must be within 0.05 mm min. to 0.5 mm max.

ORDER INFORMATION

Part Number	Marking Code	Reel Size	Quantity
SE12TQ7UDIH	ER1	7"	3,000



SE12TQ7UDIH

ESD PROTECTION DIODE

SUGGESTED SOLDER PAD LAYOUT

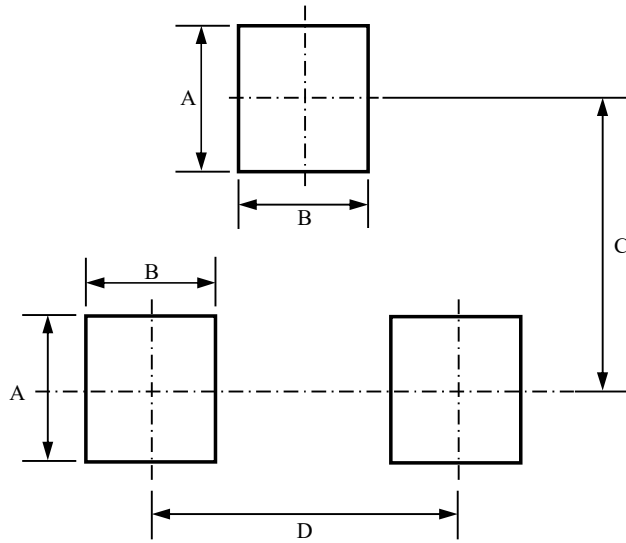

Unit :mm

PACKAGE	A	B	C	D
SOT-23	1.00	0.80	2.00	1.90