



HER201 THRU HER208

HIGH EFFICIENCY RECTIFIER

REVERSE VOLTAGE: 50 to 1000 VOLTS

FORWARD CURRENT: 2.0 AMPERE

FEATURES

- Plastic package has Underwriters Laboratory Flammability Classification 94V-O utilizing Flame Retardant Epoxy Molding Compound.
- Ultra Fast switching for high efficiency.
- High speed switching
- Suffix "H" indicates Halogen-free parts, ex. HER201H

MECHANICAL DATA

Case : Molded plastic, DO-15

Terminals : Axial leads, solderable per MIL-STD-202, method 208 guaranteed

Polarity : Band denotes cathode

Mounting position : Any

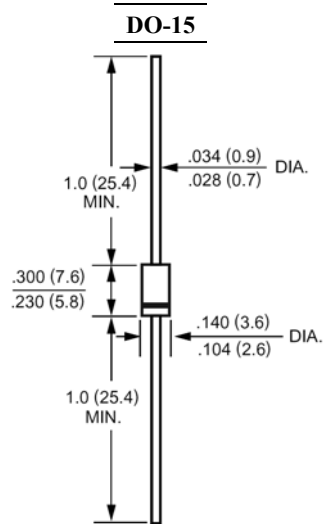

Dimensions in inches and (millimeters)

Maximum Ratings and Electrical Characteristics

Ratings at 25°C ambient temperature unless otherwise specified.

Single phase, half wave, 60Hz, resistive or inductive load.

For capacitive load, derate current by 20%.

Parameter	Symbols	HER201	HER202	HER203	HER204	HER205	HER206	HER207	HER208	Units	
Maximum Recerrent Peak Reverse Voltage	V_{RRM}	50	100	200	300	400	600	800	1000	Volts	
Maximum RMS Voltage	V_{RMS}	35	70	140	210	280	420	560	700	Volts	
Maximium DC Blocking Voltage	V_{DC}	50	100	200	300	400	600	800	1000	Volts	
Maximum Average Forward Rectified Current .375"(9.5mm) Lead Length	$I_{(AV)}$	2.0								Amp	
Peak Forward Surge Current, 8.3ms single half-sine-wave superimposed on rated load (JEDEC method)	I_{FSM}	60.0								Amp	
Maximum Forward Voltage at 2.0A and $T_A=25^\circ\text{C}$	V_F	1.0			1.3		1.7			Volts	
Maximum Reverse Current at $T_J=25^\circ\text{C}$ at Rated DC Blocking Voltage $T_J=100^\circ\text{C}$	I_R	5.0					100				uAmp
Typical Junction Capacitance (Note 1)	C_J	50					35				pF
Maximum Reverse Recovery Time (Note 2)	T_{RR}	50					75				nS
Typical Thermal Resistance (Note 3)	$R_{\theta JA}$	60.0								°C/W	
Operating and Storage Temperature Range	T_J, T_{stg}	-65 to +150								°C	

NOTES:

1- Measured at 1 MHz and applied reverse voltage of 4.0 VDC.

2- Reverse Recovery Test Conditions: $I_F=5A$, $I_R=1A$, $I_{RR}=25A$.

3- Thermal Resistance form junction to Ambient at 0.375"(9.5mm) lead length P.C.B. Mounted.



HER201 THRU HER208

HIGH EFFICIENCY RECTIFIER

RATINGS AND CHARACTERISTIC CURVES

FIG.1 TEST CIRCUIT DIAGRAM AND REVERSE RECOVERY TIME CHARACTERISTIC

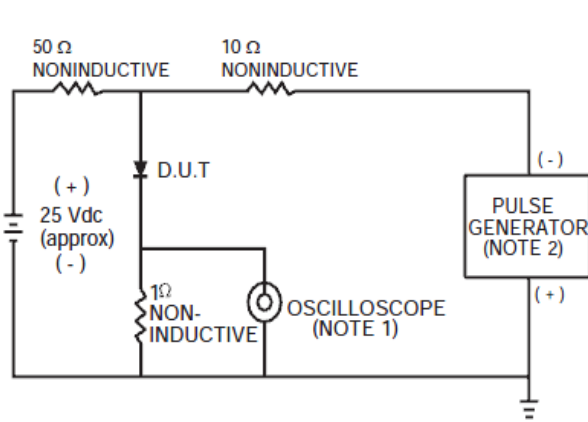

- NOTES: 1 Rise Time = 7ns max. Input Impedance = 1 megohm, 22pF.
 2. Rise Time = 10ns max. Source Impedance = 50 ohms.

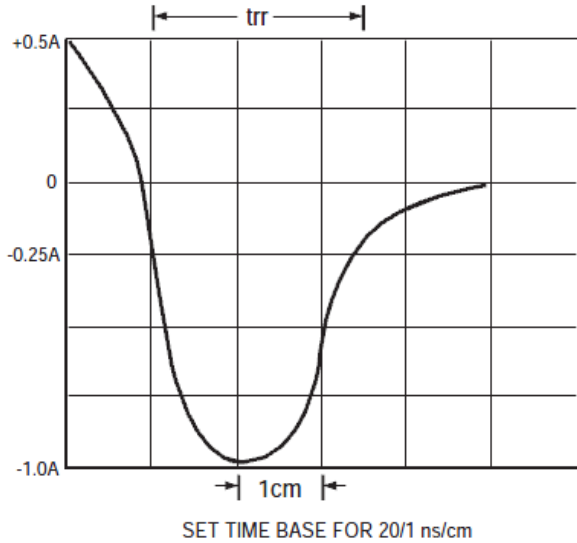

FIG.2 TYPICAL FORWARD CURRENT DERATING CURVE

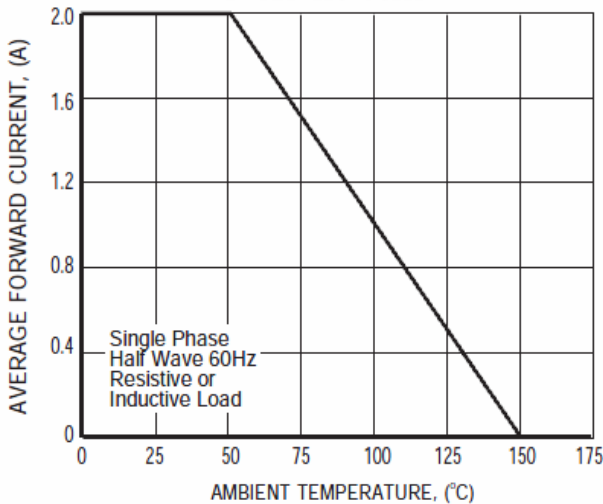

FIG.3 TYPICAL REVERSE CHARACTERISTICS

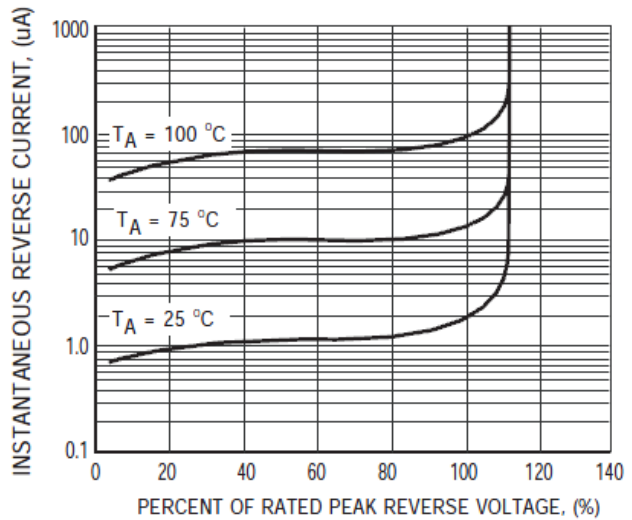

FIG.4 TYPICAL INSTANTANEOUS FORWARD CHARACTERISTICS

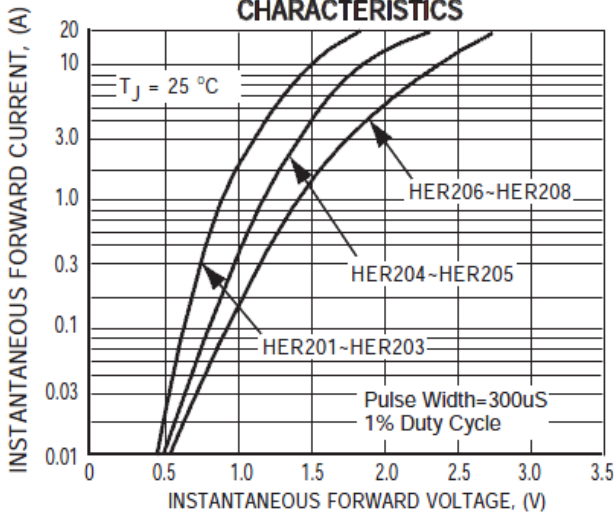

FIG.5 MAXIMUM NON-REPETITIVE FORWARD SURGE CURRENT

