

HER101G THRU HER108G

HIGH EFFICIENCY RECTIFIER

REVERSE VOLTAGE: 50 to 1000 VOLTS
FORWARD CURRENT: 1.0 AMPERE

FEATURES

- Plastic package has Underwriters Laboratory Flammability Classification 94V-O utilizing Flame Retardant Epoxy Molding Compound.
- Ultra Fast switching for high efficiency.
- High speed switching
- Glass Passivated Die Construction
- Suffix "H" indicates Halogen-free parts, ex. HER101GH

MECHANICAL DATA

Case : Molded plastic, DO-41
 Terminals : Axial leads, solderable per MIL-STD-202, method 208 guaranteed
 Polarity : Band denotes cathode
 Mounting position : Any

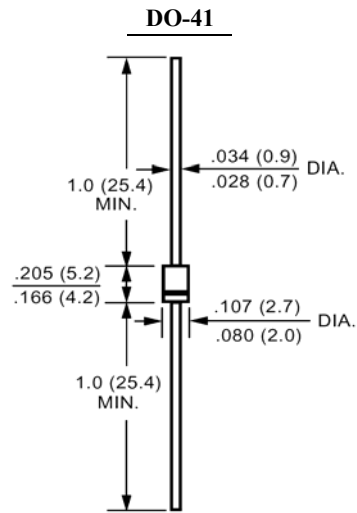

Dimensions in inches and (millimeters)

Maximum Ratings and Electrical Characteristics

Ratings at 25°C ambient temperature unless otherwise specified.
 Single phase, half wave, 60Hz, resistive or inductive load.
 For capacitive load, derate current by 20%.

Parameter	Symbols	HER101G	HER102G	HER103G	HER104G	HER105G	HER106G	HER107G	HER108G	Units	
Maximum Recerrent Peak Reverse Voltage	V_{RRM}	50	100	200	300	400	600	800	1000	Volts	
Maximum RMS Voltage	V_{RMS}	35	70	140	210	280	420	560	700	Volts	
Maximum DC Blocking Voltage	V_{DC}	50	100	200	300	400	600	800	1000	Volts	
Maximum Average Forward Rectified Current .375"(9.5mm) Lead Length	$I_{(AV)}$	1.0								Amp	
Peak Forward Surge Current, 8.3ms single half-sine-wave superimposed on rated load (JEDEC method)	I_{FSM}	30.0								Amp	
Maximum Forward Voltage at 1.0A and $T_A=25^\circ\text{C}$	V_F	1.0			1.3		1.7			Volts	
Maximum Reverse Current at $T_J=25^\circ\text{C}$ at Rated DC Blocking Voltage $T_J=100^\circ\text{C}$	I_R					5.0		100			uAmp
Typical Junction Capacitance (Note 1)	C_J	25					20				pF
Maximum Reverse Recovery Time (Note 2)	T_{RR}	50					75				nS
Typical Thermal Resistance (Note 3)	$R_{\theta JA}$	70.0								°C/W	
Operating and Storage Temperature Range	T_J, T_{stg}	-65 to +150								°C	

NOTES:

- 1- Measured at 1 MHz and applied reverse voltage of 4.0 VDC.
- 2- Reverse Recovery Test Conditions: $I_F=5A$, $I_R=1A$, $I_{RR}=25A$.
- 3- Thermal Resistance form junction to Ambient at 0.375"(9.5mm) lead length P.C.B. Mounted.

HER101G THRU HER108G

HIGH EFFICIENCY RECTIFIER



RATINGS AND CHARACTERISTIC CURVES

FIG. 1 - TEST CIRCUIT DIAGRAM AND REVERSE RECOVERY TIME CHARACTERISTIC

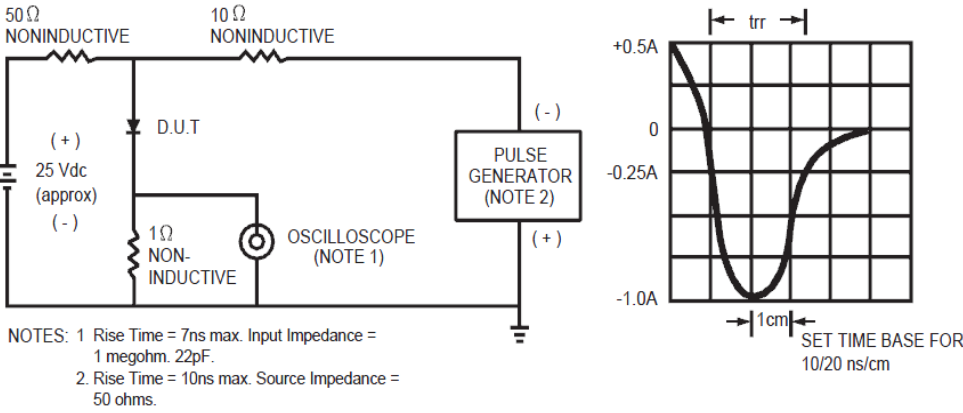

FIG. 2 - TYPICAL FORWARD CURRENT DERATING CURVE

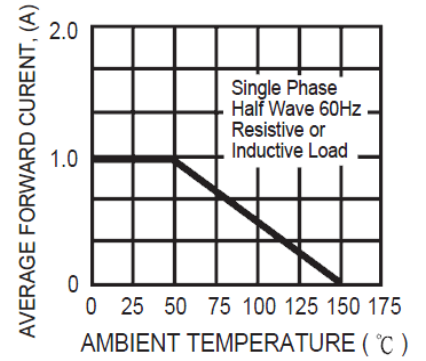

FIG. 3 - TYPICAL REVERSE CHARACTERISTICS

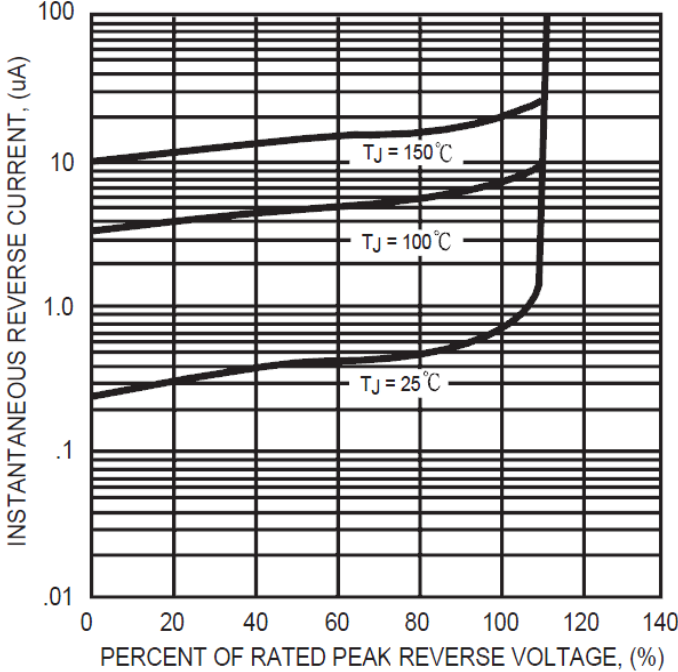

FIG. 4 - TYPICAL INSTANTANEOUS FORWARD CHARACTERISTICS

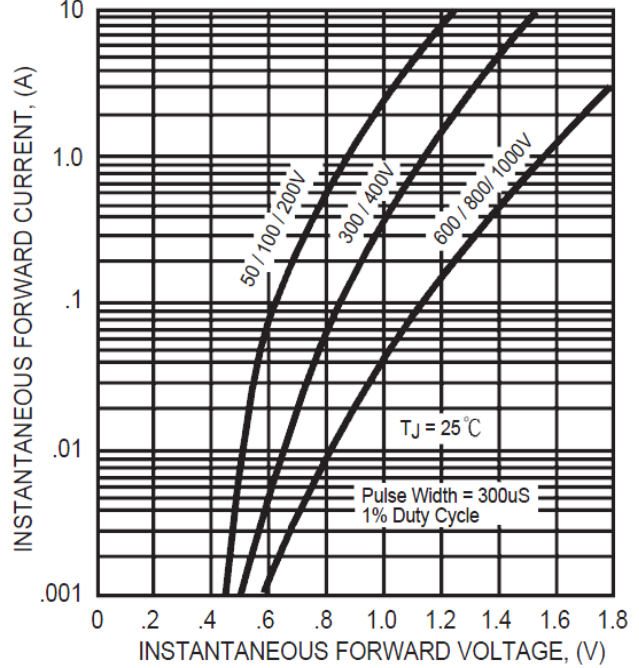

FIG. 5 - MAXIMUM NON-REPETITIVE FORWARD SURGE CURRENT

